

TORQUE SETTINGS
STAINLESS STEEL A2
 CSK M5x16 6Nm
 Socket M6 14Nm
STAINLESS STEEL A4
 Socket M6 17Nm

Note
 Use mastic sealant
 in drilled holes during
 assembly of fixings

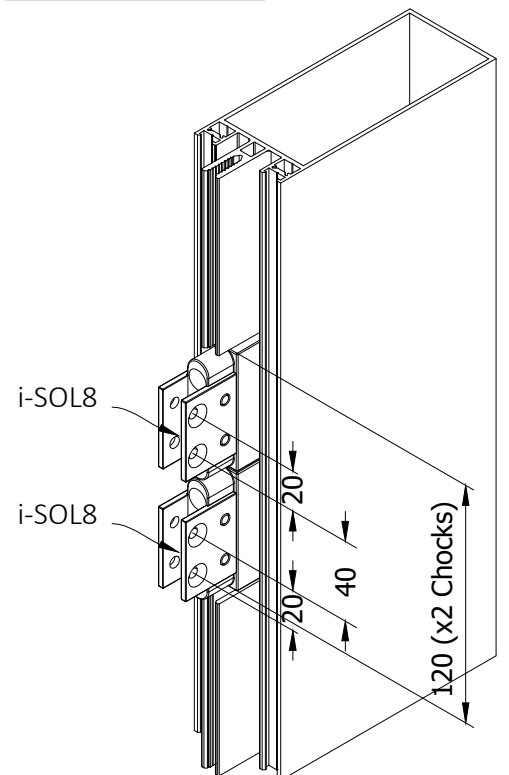

Factory Preparation

Projection 500mm - Dependant upon mullion strength for applied lateral loading

Example Vertical EXtruded Fin

Projection 500mm - Dependant upon mullion strength for applied lateral loading

Example Vertical Glass Fin

Specification
 i-SOL8 Thermally Broken curtain wall bracket adaptor manufactured from Carbon Fibre.
 To guarantee zero interstitial condensation risk.
 To attain a minimum ultimate strength of 2kNm combined with a Chi heat loss value of no more than 0.04 W/K.

Note
 Lateral loading may be very high in this application scenario. Consult your structural engineer if in doubt regarding the strength of the mullion - it must be both strong enough to accept the elevation load and the lateral load combined.
 Removal of the mullion screw port nose detail locally to the bracket is necessary to prevent excessive lateral deformation of the fin.
 The internal tapping plate should allow access for any mullion reinforcement profile necessary to comply with loading requirements.

i-SOL8

Date July20	Issue 220v1	Blue Sky Concept Design Ltd
Title i-SOL8 Data Sheet Typical Fix - Vertical Feature Fin		
Data Sheet Reference Number 050		