

TORQUE SETTINGS

STAINLESS STEEL A2
CSK M5x16 6Nm
Socket M6 14Nm
STAINLESS STEEL A4
Socket M6 17Nm

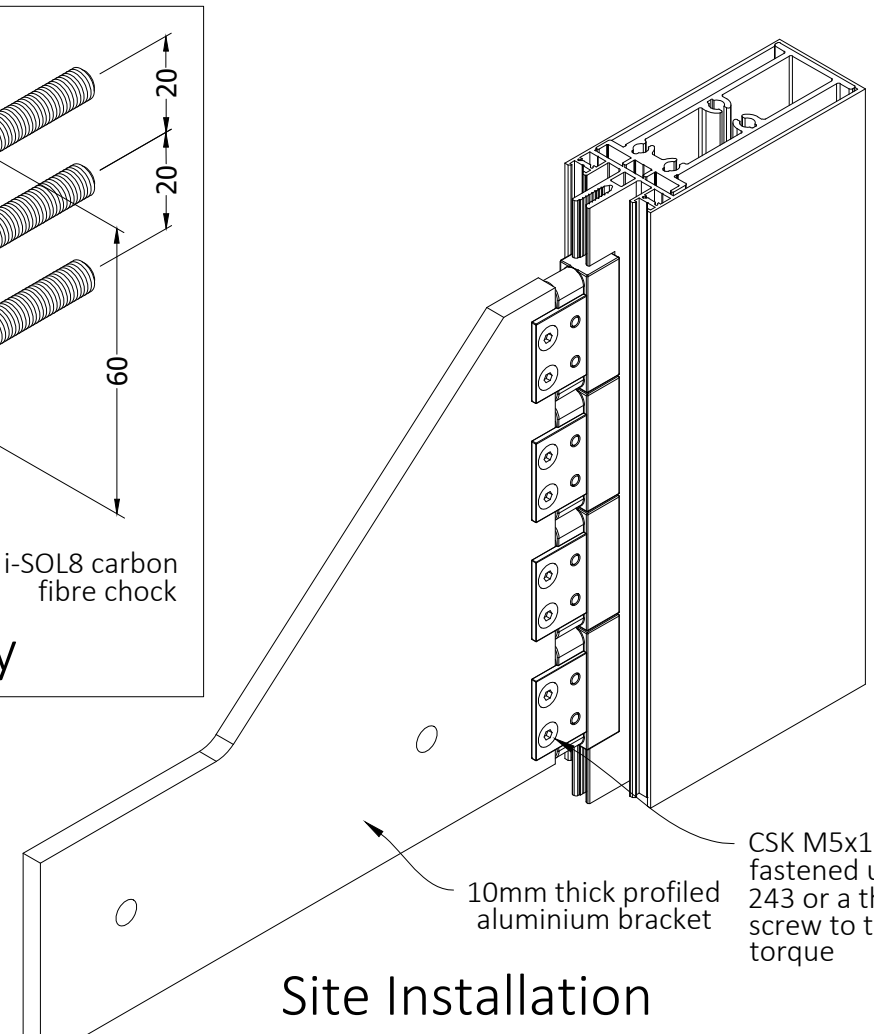

Specification

i-SOL8 Thermally Broken curtain wall bracket manufactured from carbon fibre support chocks.

To guarantee zero interstitial condensation risk.

To attain a minimum ultimate loading of 3kNm combined with a Chi heat loss value of no more than 0.07 W/K at >200mm length.

i-SOL8

Date Nov19	Issue 219v5	Blue Sky Concept Design Ltd
---------------	----------------	--------------------------------

Title
**i-SOL8 Data Sheet
Typical Fix**

Data Sheet Reference Number
010