

TORQUE SETTINGS

STAINLESS STEEL A2
CSK M5x16 6Nm
Socket M6 14Nm
STAINLESS STEEL A4
Socket M6 17Nm

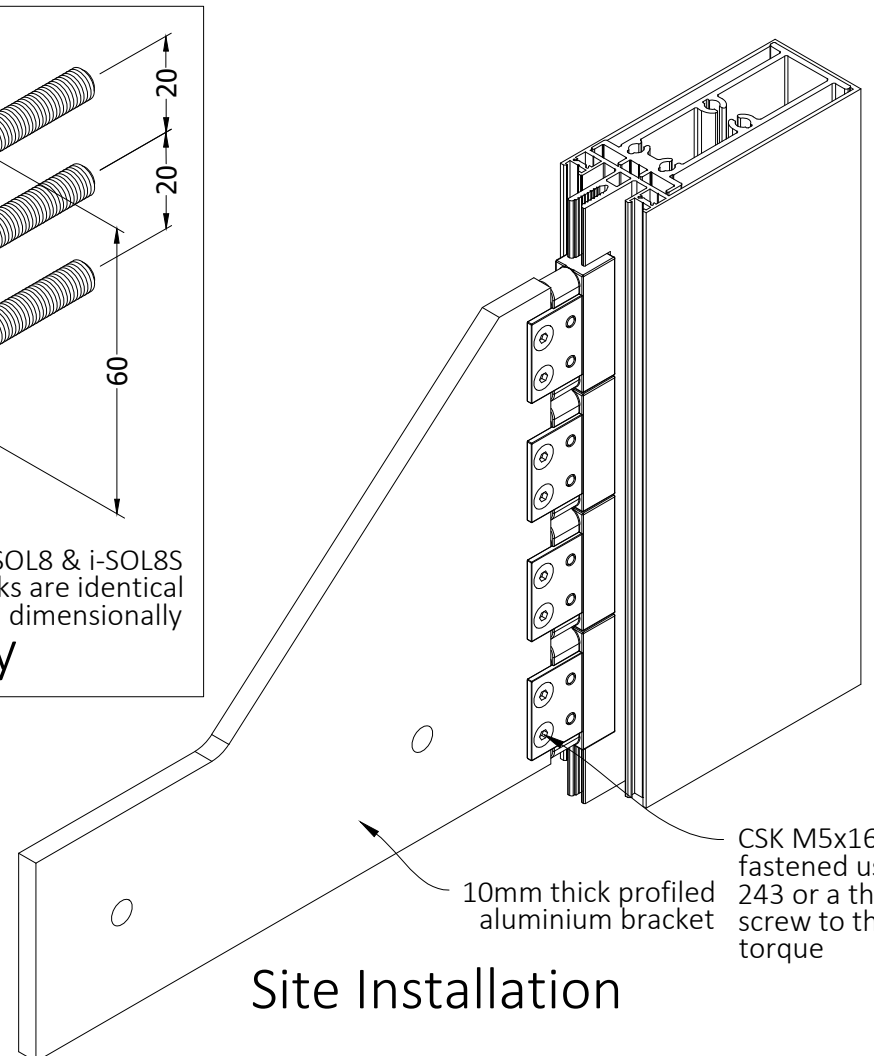

Specification

i-SOL8S Thermally efficient curtain wall bracket manufactured from carbon fibre and 304 stainless steel support chocks.

To guarantee zero interstitial condensation risk.

To attain a minimum ultimate loading of 4.5kNm combined with a Chi heat loss value of no more than 0.24 W/K.

i-SOL8S

Date Nov19	Issue 219v5	Blue Sky Concept Design Ltd
---------------	----------------	--------------------------------

Title
**i-SOL8S Data Sheet
Typical Fix**

Data Sheet Reference Number
020